

Fan Coil Units

Cooling capacity: 1,5 kW - 10,7 kW
Heating capacity: 3,7 kW - 23,2 kW

KT

Cooling/Heating

KT-VA



KT-HA



KT-CA



KT-CS

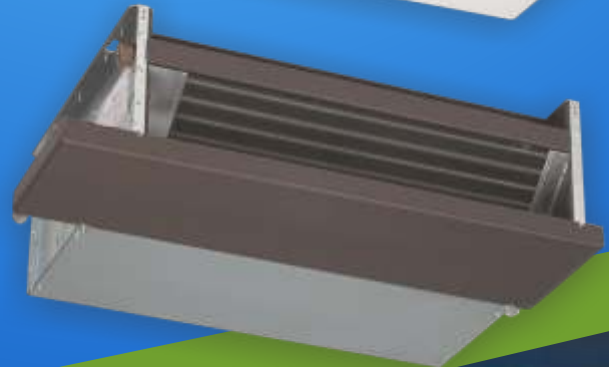

Terminal Units



Contents



pg

2	1. General Description
3	2. Technical Description
6	3. Technical Specifications
7	4. Dimensions

1. General Description



Standard Fan Coil Units



Klimallco Fan coil Units are the solution for cooling/heating applications. They are available in a wide range of models and sizes with nominal capacities ranging from 1.5 kW to 10.7 kW in cooling and 3.7 kW up to 23.2 kW in heating.

This extensive Fan Coil series is ideal in combination with Klimallco water chillers or heat pumps for airconditioning residences, offices, shops or any other commercial application where comfort conditions are required, blending in perfectly with the aesthetics of any space.

Asynchronous motors + 6-speed Autotransformer (3-speed connected in the factory)

Last generation fan made of plastic with low revolutions number, statically and dynamically balanced, superlative silent

Air supply grills with double bank adjustable louvers to send the air-flow in any direction

Highly efficient coil

Left or Right hydraulic connections

High efficiency air filter, cleanable, on turning slides for an easy extraction and maintenance

Wide variety of models, versions, accessories, variants, solutions

2. Technical Description

1.1 Cabinet

(PRE-PAINTED STEEL + ABS ADJUSTABLE LOUVERS)

(Only for versions VA – HA)

Beautiful, modern styled cabinet well proportioned smoothed outline to perfectly match with any interior. Standard white colour (similar to RAL 9010), or any other RAL colour on request (additional charge).

Made of thick steel-sheet, galvanized and finished by a polyvinyl chloride film, to make it resistant to rust, corrosion, chemical agents, solvents, aliphatic and alcohols. Top film about 10 times thicker than standard one treated by epoxy powder (for extra resistance to scratch). Thermo acoustic internal insulation (class M1). Well-balanced proportions, just 220 mm thick.

Air delivery grill is in white ABS (similar to RAL 9002, slightly in contrast with the cabinet white colour) with

sliding side doors to easily access to the internal control panel (option).

The double bank grill's louvers can be easily singularly manually adjusted, allowing to have air-flow in Any Wished Direction (front, back, right, left, uni-directional, bi-directional, opposite-position, etc...):

- Louvers adjusted in opposite position will increase the Induction Effect
- Some Louvers closed will increase the air-flow speed increasing the Air Throw
- Adjusting the air-flow tangentially to the ceiling/wall will increase the Coanda Effect
- All Louvers closed when the unit is not in use, will Avoid the Dust and Dirtiness to get in.

1.2 Main Casing

Main casing (Bearing structure) made of extremely thick steel-sheet, resistant to rust, corrosion, chemical agents, solvents, aliphatics and alcohols.

Self-supporting and removable panels provided with holes (buttonholes) for ceiling/wall mounting directly through the main casing.

Pre-cuts slots and prearranged holes to configure the unit on request, to install the accessories, to output for the water connections on the left or right, to reverse the unit even on-site.

Assembled with self-threading screws for fast, total and easy check/maintenance. Reduced sizes, optimised volumes.

Available in a very large range of horizontal and vertical versions.

Available main casings:

- Z : Single skin panel made of galvanized steel + internal thermal-acoustic insulation (class M1) of all parts in contact with the coil for all KT -CS/CA models.

1.3 Drain Pan (with Thermal Insulation)

Drain pan provided with condensation drain and thermal insulation (class M1).

Only for vertical versions: Condensation Drain Funnel with 20 mm pipe, realised in plastic material (standard supplied in the same side of the water connections)

terminating externally to the unit side, for an easy and fast connection to the condensation drain pipe.



1.4 Heat Exchanger (standard Unit With Water Coil)

Highly efficient coil (Turbolenced Fins with a high number of Reynolds) made of copper pipes and aluminium fins fixed by mechanical expansion. Coil connections provided with anti-torsion system, manual air vent valves, manual water drain valves. Standard connections on the left side; on request (no additional charge) connections on the right side, anyway can be easily reversed even on working site.

1 coil for a 2-pipe system; 2 coils for a 4-pipe system.

Coils tested at 30 Bar pressure, suitable to work with water at max 15 Bar pressure.

Coils designed to work with hot water (boiler), low temperature hot water (condense boiler, solar energy system, hot water pump, etc.), high temperature hot water (industrial processes and/or high temperature boiler), chilled water (chillers and/or industrial processes), water added with glycol.

1.5 Fan Section (centrifugal Fan Of Last Generation)

Fan section including 1, 2 or 3 centrifugal fans with double air inlet

Last Generation Plastic Blades (forward curved fins) directly coupled to the electric motor. Mounted on elastic and anti-vibration supports. Fan section statically and dynamically balanced.

Extensive diameter fans (= high air flow and high static pressure) with low revolutions (= low noise level).

Asynchronous electric motor provided with heat protection (Klixon), running capacitor permanently switched on, IP 42, Class B, electric cables protected by double insulation.

Manufactured according with international standards, 230Vac-1Ph-50Hz.

Fan section easy to remove (fixed by just 4 screws).

- Standard unit provided with single-speed motor + Autotransformer with 6 outputs in order to have 6 equal-distance speed (with performances changing from max=100% up to min = about 50%). Autotransformer is installed externally, on the unit side, to enable easy maintenance operations.
- This technology warrantee a big flexibility, with possible connections according with the specific end-user needs, higher or lower speeds choices between the 6 available.

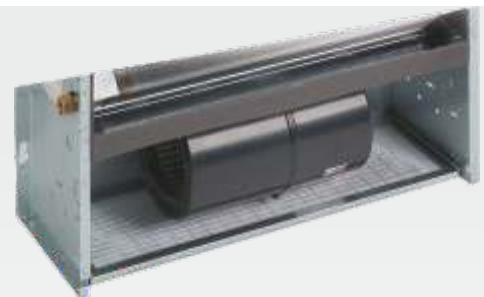

1.6 AIR INTAKE AND SUPPLY OUTLETS Without Grills/protections

All versions without cabinet, are standard supplied open (air intake and air supply), without any grill/protection.

WARNING: it is prohibited to make the unit operate if both the outlets of the unit are not ducted or protected by grills or safety net.

1.7 Air Filter (high Efficiency Standard)

Air filter easy to remove, made of a metal frame holding filtering section. Can be regenerated by water wash, blowing, suction.

- Standard: Filtering media made of acrylic polyester fabric, being resin treated, highly efficient. Superlative against Powders and Pollens.
- Class M1; Filtering level EU3 (EUROVENT 4/5).



1.8 Electrical Equipment (necessary Additional Accessory)

The standard unit is supplied equipped only with the motor cable (without control panel) terminal.

In this way, the client can choose among a large range of control panels "CB"- "CBE" and terminal

boards "MRS" (available as accessories), which are supplied mounted or loose on the unit (standard on opposite to water connection side).

1.9 EXTENDED DRAIN PAN (Optional)

Single slope drain pan for optimised condensate drainage, provided with drainpipe (standard on the same side of coil connections).

1.10 ACCESSORIES

Supplied on request, mounted or not mounted

Standard unit supplied with air filter, Drain Pan, 3-way Valves, Wall Mounted Control, Shut of valves



Drain pan



Wall mounted thermostat



Electrical Resistance

DECLARED PERFORMANCES IN THE CATALOGUE

Nominal performances and air flows, according to the reference norms, referred to:

Nominal air flows referred to no resistance on the air inlet or outlet (unit with dry coil, without air filter, no intake grill or supply grill, even because the unit can be supplied with different type of filter / grills / accessories, with different pressure drops, having

different air flow, and consequent different performances). We recommend to select one unit always considering sufficient static pressure, in order to take into account the pressure drops due to dirty filter, wet coil in cooling conditions, installed grills, air ducts, etc...

3. Technical Specifications

2-pipe models

Type	KT	130	230	330	430	530	630	730	830	930	930P	1030	1030P	1130P	1230P
Cooling capacity	Total (1) W	1.500	2.000	2.530	3.020	3.750	4.250	5.520	6.420	7.530	8.140	9.020	9.820	9.600	10.710
	Sensible (1) W	1.290	1.620	2.070	2.310	2.870	3.230	4.330	4.800	5.670	6.200	6.620	7.300	7.640	8.360
Heating capacity (2)	W	3.740	4.910	5.980	6.710	8.160	9.440	12.000	13.300	15.500	16.830	18.100	19.790	21.100	23.200
Nominal Air flow (3) m ³ /h		370	400	500	550	670	720	1.000	1.050	1.280	1.450	1.310	1.500	1.910	1.940
Water flow (4)	Cooling l/h	258	344	436	520	645	731	950	1.105	1.296	1.401	1.552	1.690	1.652	1.843
	Heating l/h	322	423	515	578	702	812	1.032	1.144	1.333	1.448	1.557	1.702	1.815	1.996
Water pressure drops (5)	Cooling l/h	13,1	16,3	18,5	20,8	22,6	24,1	24,5	27,1	28,8	33,7	29,2	34,6	31	33,4
	Heating l/h	15,9	19,2	20,1	20	20,9	23,2	22,6	22,7	23,8	28	22,9	27,4	29,2	30,6
Sound levels (6)	Min-Med-Max	24-31-38	25-31-38	30-38-44	31-38-45	26-33-37	27-34-37	34-41-43	35-41-45	39-46-48	43-48-51	40-46-49	44-49-52	45-48-51	46-48-51
Motors/Fans	No/No	1/1		1/1		1/2		1/2		1/2	1/2	1/2	1/2		1/3
Nominal current input	Max(7) W	55W		85W		75W		145W		175W	225W	175W	225W		285W
	Max(7) A	0,25A		0,40A		0,35A		0,65A		0,77A	1,0A	0,77A	1,00A		1,30A
Power supply		230Vac – 1Ph – 50Hz													
Heating/cooling coil	Rows	3R		3R		3R		3R		3R	3R	3R	3R	3R	3R
	Connections DN	1/2" F		1/2" F		1/2" F		1/2" F		1/2" F	1/2" F	1/2" F	1/2" F	1/2" F	1/2" F
Drain pipe	φ(mm)	20		20		20		20		20	20	20	20	20	20
Main dimensions	L mm	670		870		1.070		1.270		1.470	1.470	1.470	1.470	1.670	1.670
	M mm							520							
	H mm							220							

4-pipe models

TYPE	KT	131	231	331	431	531	631	731	831	931	931P	1031	1031P	1131P	1231P
Cooling capacity	Total (1) W	1.450	1.940	2.470	2.920	3.650	4.110	5.390	6.230	7.350	7.970	8.810	9.620	9.420	10.510
	Sensible (1) W	1.240	1.570	2.020	2.220	2.780	3.110	4.210	4.640	5.520	6.050	6.440	7.130	7.470	8.180
Heating capacity (2)	W	1.880	1.980	3.180	3.350	4.380	4.550	6.290	6.460	7.990	8.700	8.110	8.900	11.090	11.200
Nominal Air flow (3)	m ³ /h	350	380	480	520	640	680	960	1.000	1.230	1.400	1.260	1.450	1.850	1.880
Water flow (4)	Cooling l/h	250	334	425	503	628	707	928	1.072	1.265	1.371	1.516	1.655	1.621	1.808
	Heating l/h	162	171	274	289	377	392	541	556	688	749	698	766	954	964
Water pressure drops (5)	Cooling kPa	12,3	15,4	17,6	19,5	21,4	22,5	23,4	25,5	27,4	32,2	27,9	33,2	29,8	32,1
	Heating kPa	7,3	8,1	11,7	13	21,3	23	41,1	43,4	37,8	44,7	38,9	46,8	48,4	49,4
Sound levels (6)	Min-Med-Max dB(A)	24-31-38	25-31-38	30-38-44	31-38-45	26-33-37	27-34-37	34-41-43	35-41-45	39-46-48	43-48-51	40-46-49	44-49-52	45-48-51	46-48-51
Motors/Fans	No./No.	1/1		1/1		1/2		1/2		1/2	1/2	1/2	1/2	1/3	1/3
Nominal current input	MAX(7) W	55W		85W		75W		145W		175W	225W	175W	225W		285W
	MAX(7) A	0,25A		0,40A		0,35A		0,65A		0,77A	1,00A	0,77A	1,00A	1,30A	1,30A
Power supply		230Vac – 1Ph – 50Hz													
Cooling coil	Rows No.	3R		3R		3R		3R		3R	3R	3R	3R	3R	3R
	Connections DN(*)	1/2" F		1/2" F		1/2" F		1/2" F		1/2" F	1/2" F	1/2" F	1/2" F	1/2" F	1/2" F
Heating coil	Rows No.	1R		1R		1R		1R		1R	1R	1R	1R	1R	1R
	Connections DN(*)	1/2" F		1/2" F		1/2" F		1/2" F		1/2" F	1/2" F	1/2" F	1/2" F	1/2" F	1/2" F
Drain pipe	φ(mm)	20		20		20		20		20	20	20	20	20	20
Main dimensions	L mm	670		870		1.070		1.270		1.470	1.470	1.470	1.470	1.670	1.670
	H mm							520							
	S mm							220							

Notes

Technical data refer to the following conditions: Standard unit – Atmospheric pressure 1013 mbar - Power supply 230Vac/1Ph/50Hz.

(1) (2) (3) (4) (5): Nominal technical data, refer air flow (3) to the max speed and unit with free air flow (External static pressure ESP=0Pa).

(1) Cooling: Air temp.: 27°Cd.b., 19°Cw.b. – Entering/leaving water temp. 7/12°C – Max speed (ref. air flow (3)). For different air flows (ex. Med and/or Min speed and/or ESP

> 0Pa): ref. nominal air flows, entering water temp. 7°C and water flow as for Max speed (4).

(2) Heating: Air temp.: 20°C – Entering/leaving water temp. 70/60°C – Max speed (ref. air flow (3)). For different air flows (ex. Med and/or Min speed and/or ESP > 0Pa): ref. nominal air flows, entering water temp. 70°C and water flow as for Max speed (4).

(1) (2) Cooling and Heating capacities: Data calculated by SW and measurements made in calorimetric room ref. UNI 7940 part 1°-2°, UNI-EN 1397/2001 standards.

(3) Air flow and Static pressure: Nominal data measured with casing ref. AMCA210-74 fig.12 standards and plenum + diaphragm ref. CNR-UNI 10023 standards.

(6) Sound Levels: Free field sound pressure, 2 m distance. Data calculated based on sound power measured in riverberation room ref. ISO 3741 - ISO 3742 standards.

(7) Electrical data: Data measured with Wattmeter Jokogawa WT110 (Max value, nominal, of motor label = reference value for the electrical system design).

*** Capacities for different conditions can be calculated through selection software.
Please consult our technical department.**

4. Dimensions

KT - VA

Dimensions in mm

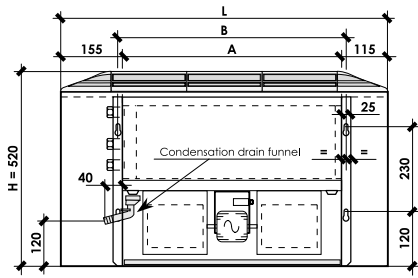

Water connections

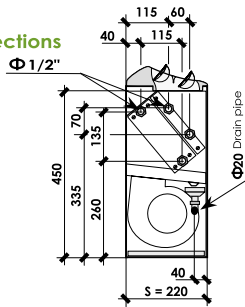

MODEL	2-pipe KT-VA		130	230	330	430	530	630	730	830	930 (P)	1030	1130P	1230
	4-pipe		131	231	331	431	531	631	731	831	931 (P)	1031	1131P	1231
Dimensions	L	mm	670	670	870	870	1070	1070	1270	1270	1470	1470	1670	1670
	H	mm	520	520	520	520	520	520	520	520	520	520	520	520
	S	mm	220	220	220	220	220	220	220	220	220	220	220	220
	A	mm	400	400	600	600	800	800	1000	1000	1200	1200	1400	1400
Net weight	2-pipe	Kg	13,5	14	16,4	17,2	22,5	23,5	26	27,5	30	31,5	34	37,5
	4-pipe	Kg	14,4	14,9	17,4	18,2	23,6	24,6	27,2	28,7	31,3	32,8	35,4	38,9

KT - CA

Dimensions in mm

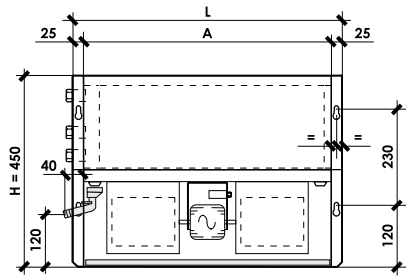

Water connections

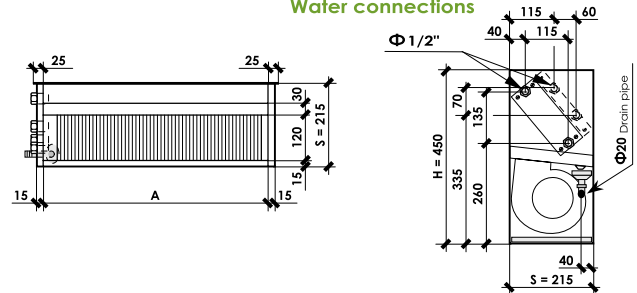

MODEL	2-pipe KT-CA		130	230	330	430	530	630	730	830	930 (P)	1030	1130P	1230
	4-pipe		131	231	331	431	531	631	731	831	931 (P)	1031	1131P	1231
Dimensions	L	mm	450	450	650	650	850	850	1050	1050	1250	1250	1450	1450
	H	mm	450	450	450	450	450	450	450	450	450	450	450	450
	S	mm	215	215	215	215	215	215	215	215	215	215	215	215
	A	mm	400	400	600	600	800	800	1000	1000	1200	1200	1400	1400
Net weight	2-pipe	Kg	10,7	11,2	13,5	14,3	19,5	20,5	23	24	27	28	31	34
	4-pipe	Kg	11	11,5	13,8	14,6	19,8	20,8	23,3	24,8	27,3	28,8	31,2	34,7

KT - HA

Dimensions in mm

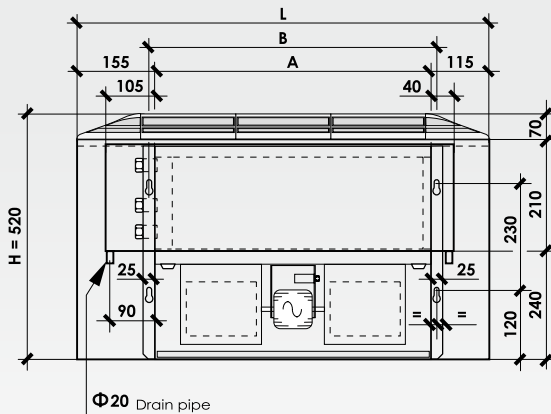
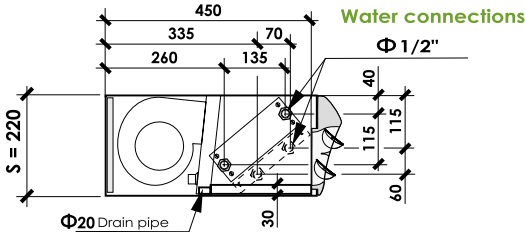

MODEL	2-pipe KT-HA		130	230	330	430	530	630	730	830	930 (P)	1030	1130P	1230
	4-pipe		131	231	331	431	531	631	731	831	931 (P)	1031	1131P	1231
Dimension s	L	mm	670	670	870	870	1070	1070	1270	1270	1470	1470	1670	1670
	H	mm	675	675	675	675	675	675	675	675	675	675	675	675
	S	mm	220	220	220	220	220	220	220	220	220	220	220	220
	A	mm	400	400	600	600	800	800	1000	1000	1200	1200	1400	1400
Net weight	2-pipe	Kg	15	15,5	18,2	19	24,6	25,6	28,4	29,9	32,7	34,2	37	40,5
	4-pipe	Kg	15,9	16,4	19,2	20	25,7	26,7	29,6	31,1	34	35,5	38,4	41,9

KT - CS

Dimensions in mm

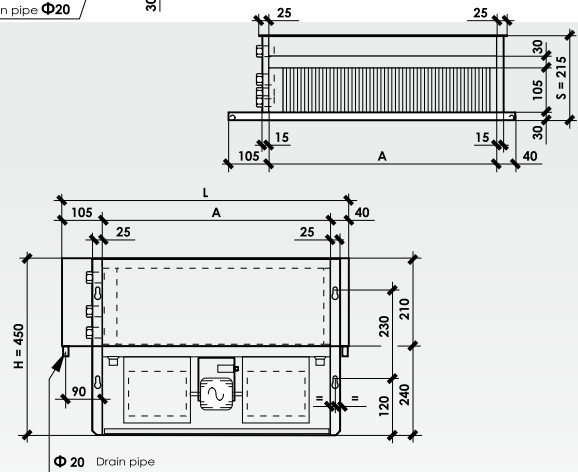
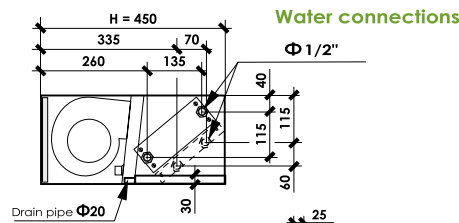

MODEL	2-pipe KT-CS		130	230	330	430	530	630	730	830	930 (P)	1030	1130P	1230
	4-pipe		131	231	331	431	531	631	731	831	931 (P)	1031	1131P	1231
Dimensions	L	mm	545	545	745	745	945	945	1145	1145	1345	1345	1545	1545
	H	mm	450	450	450	450	450	450	450	450	450	450	450	450
	S	mm	215	215	215	215	215	215	215	215	215	215	215	215
	A	mm	400	400	600	600	800	800	1000	1000	1200	1200	1400	1400
Net weight	2-pipe	Kg	11,1	11,6	13,9	14,7	19,9	20,9	23	25	27	29	31	35
	4-pipe	Kg	11,4	11,9	14,2	15	20,2	21,2	23,7	25,2	27,7	29,2	31,6	35,1

CE KLIMALLCO's units comply with the European regulations, that guarantee the safety of the product.

KT

KLIMALLCO S.A.
Manufacturers Of Air Conditioning Equipment
Tripio Lithari, Mandra Attiki - Greece P.O. Box: 15, 19 600
Tel : +30 210 5550360 / FAX : +30 210 5551919
e-mail: info@klimallco.gr <http://www.klimallco.com>

Klimallco sa Air Treatment Experts



KLIMALLCO's quality management system is certified according to **ISO 9001:2015** and **ISO 14001:2015** for:
Design, manufacturing and trading of air conditioning equipment.

Technical Data
2020